

Lites

Lites F200 II white

Owners `s & Service manual



Read this manual totally and carefully follow all the instructions contained. File this manual for future use. It is essential to read all the information contained to ensure installation, service and full operation of the Lites F200 II.

All operations must be accomplished, handled and carried out by qualified personnel only. Not complying with given notice will void warranty and will free manufacturer from any liability/responsability

www.litessrl.com

Unpacking

Unpack the carton and gently remove Lites F200 II from the box. Ensure Lites F200 II received is integer from origin in all its components.

In the event the Lites F200 II shows any damage, do not use it and contact immediately your transporter as well as your seller.

Items in the carton consist of:

- Lites F200 II luminaire
- Colour frame
- Blue Neutrik PowerCon connector
- This owner's and service manual

Safety information for the use of the Lites F200 II as well as its periodical maintenance"

- Lites F200 II is for professional use only and NEVER for domestic use therefore refrain from this latter utilisation.
- Users must scrupulously comply with information that follows, any other use in contrast will void warranty and will free the manufacturer of any sort of responsibility and liability.
- Never use Lites F200 II on any flammable surfaces.
- Minimum distance from any flammable source is of 0.25m.
- Minimum throw distance from illuminated surface: 0.5m.
- Installation of the unit(s) must be secured with adequate clamps, safety cords, nuts and bolts to bear the weight of the whole unit(s)
- Always Power Lites F200 II to safety circuit breakers. Lites F200 II must NOT and CAN NOT be operated via Phase Control Dimmer.
- Install Lites F200 II in ventilated ambient which temperature must not trespass 35°C
- Some outer parts of the LitesF200 can reach temperatures of up to 60C° when in operation.
- Lites F200 II must be fitted with protection shields (Lenses)
- On no account, directly or indirectly, LED must be touched
- Always disconnet power, (always double check that power is off) before any Service/Operation of the unit.
- Lites F200 II is rated Class I.
- Earth connection is MANDATORY!

An essential and periodically throughout cleaning of the Lites F200 II is recommended. This practice avoids that layers of dust and other impurities jeopardise and reduce the correct operation of the unit. Lenses must be cleaned to remove layers of dust that may impede and or reduce the passage of the light through the lenses. The correct and periodically maintenance keeps also fans and vents clean to keep the LitesF200 in its best performance conditions. Never touch the Yellow core of the LED both directly or indirectly nor use solvents that can damage the LED irremediably. Protection shields if battered, must be replaced with new ones (Lenses)

CE APPROVALS

The Lites F200 II products to which this manual refers to, complies with European directive pursuant to:

2014/35/EU safety of electrical equipment supplied at low voltage (LVD)

2014/30/EU Electromagnetic compatibility (EMC)

2011/65/EU Restriction of the use of certain hazardous substances (RoHS)

WARRANTY

A 24-month warranty is granted on the LitesF200 from its purchase's date. Warranty covers fabrication defects only, unit will not be replaced but will be 100% fixed. Warranty is immediately voided if the Lites F200 II has not been handled by qualified personnel. Any improper and unauthorised use, such modification(s) or misapplication of the unit will also void the warranty of the product(s). Silver colour label showing technical data and serial number, if removed or if data are impaired to render details illegible, will immediately void the warranty.

Technical specifications

Power Supply:	100/240V~ 50/60Hz (autosetting)
Maximum power consumption	240W
Stand-by power consumption	4W
LED Colour temperatures and CRI :	97
Fresnel Lens: Ø 150mm	
Colour frame dimensions: 195x185 mm (the use of standard 185x185mm colour frame is totally accetable)	
Aluminium die-caste body to maximize heat dissipation	
Operating temperature range:	-15°C + 35° C
Maxium temperature on the Lites F200 II	+60°C
Weight of the unit: Kg 7,5	
Worm-gear beam adjustment on standard Lites200F II	
Rear handle for good grip of unit ; side-lock on mounting yoke to adjust and set unit to position.	
Beam angle: 16°-68°	
Working position: +90°/-90° on vertical axe	
Protection rating: IP 20	
DMX 512 , RDM, Protocols (wireless on request)	
Neutrik powercon IN & OUT connectors	
Neutrik XRL5 IN & OUT signal connectors	
4-digit display	
Manual operation via 4-digit display	
Idle fan mode for totally silent use of the unit.	
Adjustable LED frequency	
Selection of four LED dimming curves	
Comply with CE	
Dimensions: see figure	

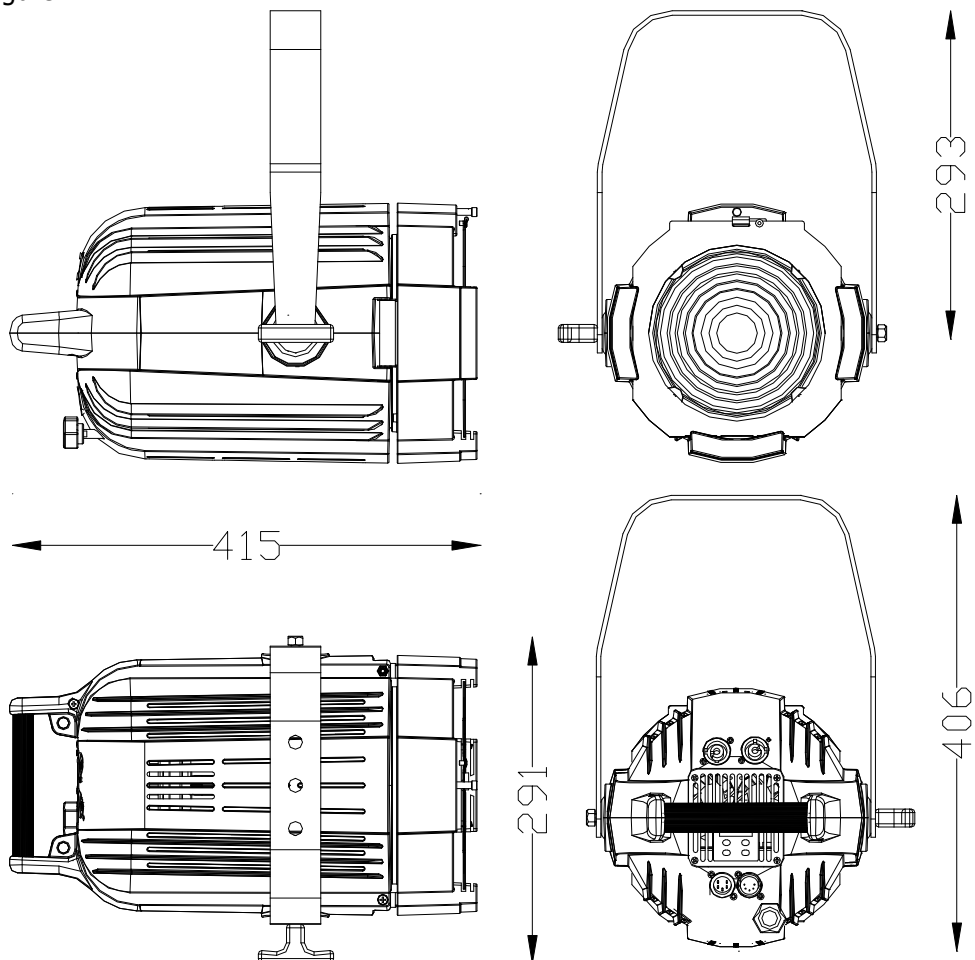

Lites200F installation

Lites F200 II is delivered with a robust yoke which hosts 3 x 12 mm mounting holes.

The use of an adequate G-clamp to sustain at least twice the weight of the Lites F200 II (Lites 200F II weighs 6,9 kg) and/or M10 screw is mandatory. The use of safety chain(s) to sustain twice the weight of the Lites F200 II is also mandatory, the safety chain adds more protections to users and third-parties. Eye-lid for the safety chain is provided on the Lites F200 II. (see Fig)

The Lites F200 II yoke revolves on 360° on the projector's axis. Lites F200 II can be installed $\pm 90^\circ$ on the vertical axis. (see Fig.). Best Lites F200 II 's performances are achieved if unit is installed as shown in the illustrations that follows. (never install Lites F200 II upsidedown, illustrations that follows show installation positions that must be avoided) . Incorrect installation(s) can, immediately or in short/long terms, jeopardise the correct operation of the Lites F200 II. Incorrect installations may void the warranty of the unit.

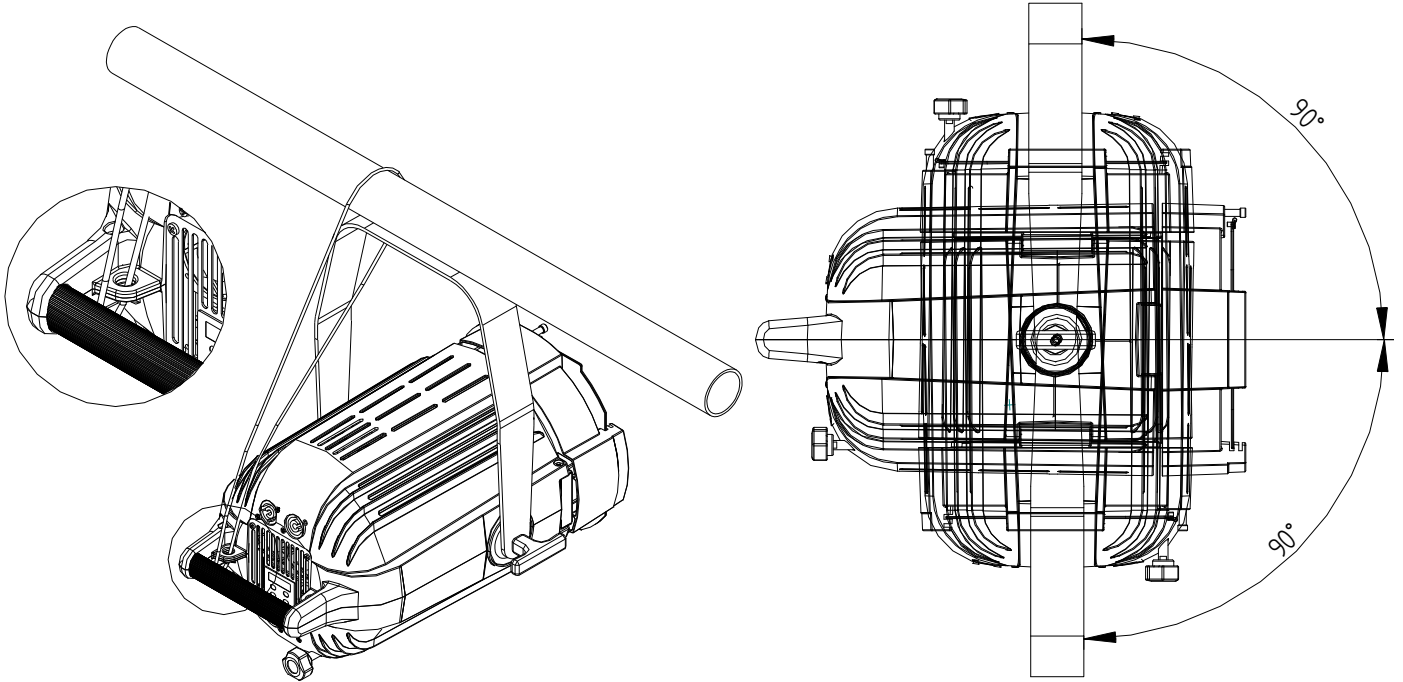

AVOID INCORRECT INSTALLATIONS AS ILLUSTRATED

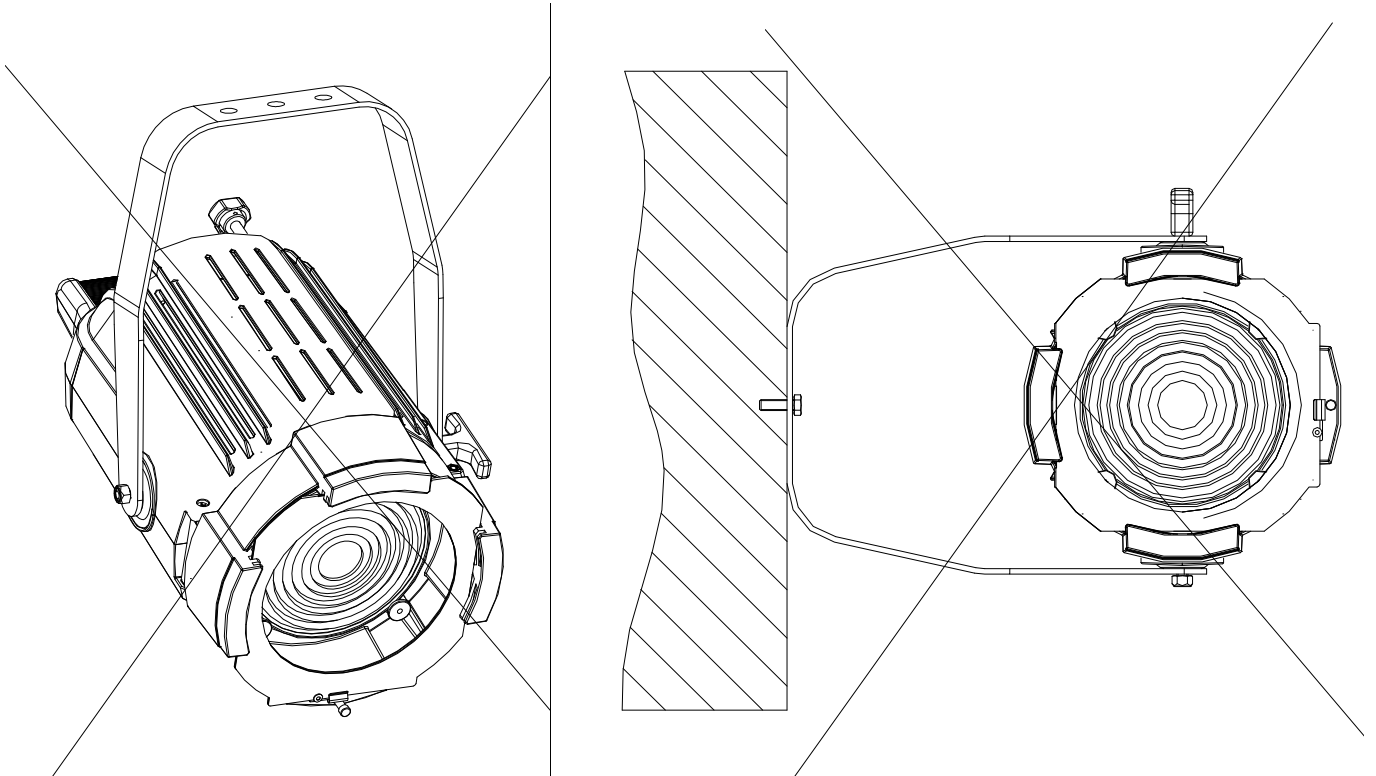

Installations of the accessories

Lites F200 II is delivered with a standard 195x185mm colour frame (standard colour frame 185x185 can also be used). The LED source used on LitesF200 allows the use of colour filters that cannot be used with high wattage tungstene lamps which would impair colour filters. Optional and standard 185x185 mm 4-leaf-barndoor can also be installed in the provided gates. Ensure that accessories when installed on the LitesF200 are securely fitted in the gates and that are triggered and secured by the spring-lock provided. (see figure)

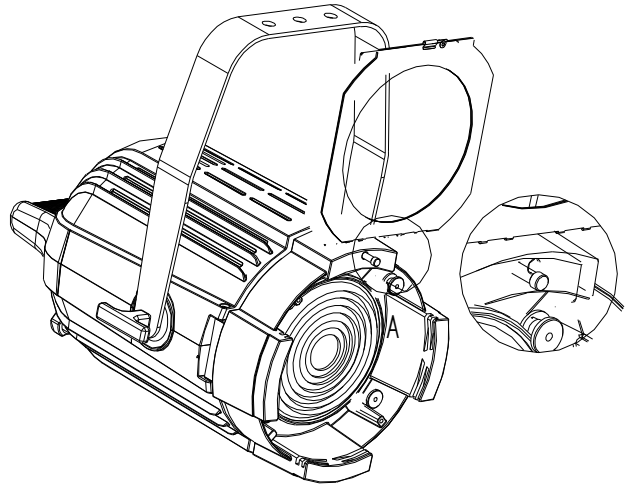

Beam adjustment

Lites F200 II can revolve $\pm 90^\circ$ upwards and $\pm 90^\circ$ downwards on the axis of the luminaire. When correct position is set to position, secure it by tightening the provided side knob. Beam adjustment is achieved via rear Helicoidal screw. Turn clockwise to narrow beam, conversely beam widens.

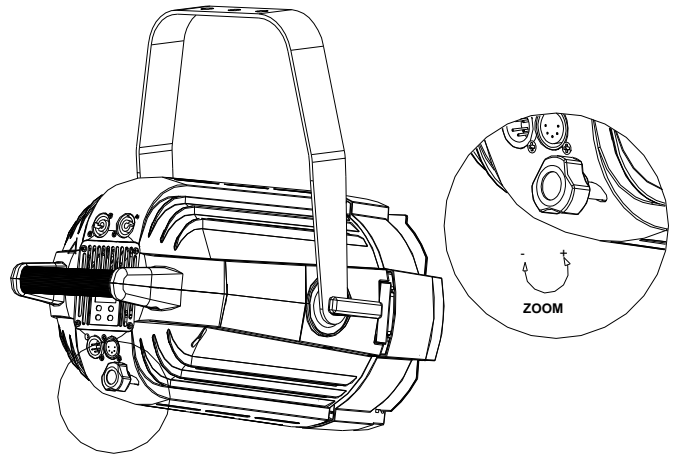

Connection to mains

WARNING ! Installation(s) must be accomplished, handled and carried out by qualified personnel only and must comply with all norms in force in the installation's country

Lites F200 II is supplied with a free Blue Neutrik PowerCon plug that must be wired using a 3x1.5mm² lead , additional specifications include:

- Operating Voltage: 300/500V
- Test Voltage: 2KV
- Operating Temperature: -10°C / +100°C

Connect blue wire to N terminal, brown wire to L terminal and Yellow/Green wire to earth terminal. (see also illustration fig) Ensure connections to safety circuit breaker at all times. Daisy chain of up to maximum 8 units if connected to 230VAC. Daisy chain of up to maximum 4 units when connected to 110VAC. Maximum daisy chain length: 25m.

WARNING: LitesF200 CANNOT be powered by using an angle phase dimmer pack
Collegamento alla rete elettrica

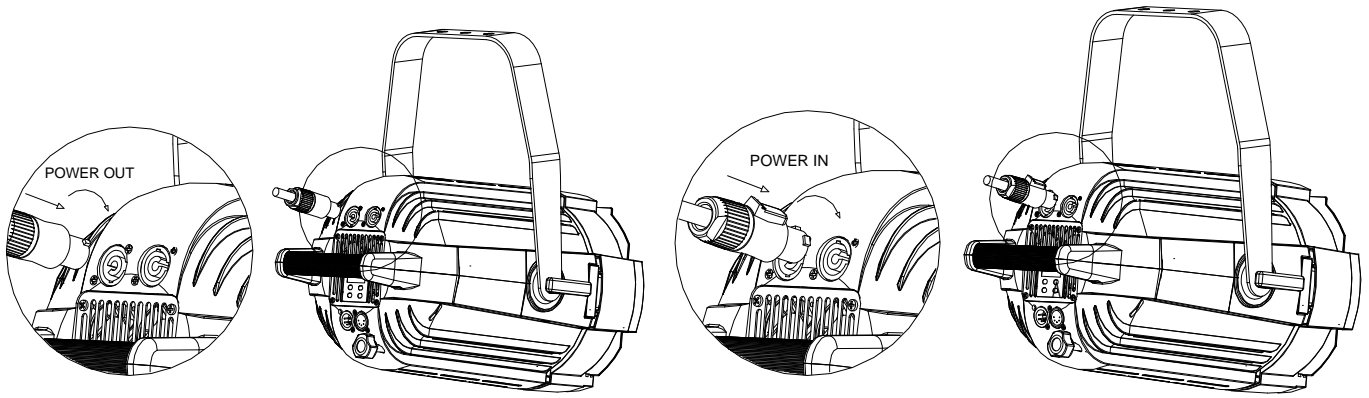

Signal Control Connection

Lites F200 II can be operated via either DMX512A and or RDM ready . For dasy chain connection use a -2 x 0,5 mm² size lead wire plus shield. Connect Pin 1 to ground, 2= data – while Pin 3 = data +. Pins 4 & 5 are not connected. Ensure that DMX wires and shield do not interfere,nor touch each other as well as they must not touch/interfere with the body of the unit . (DMX connectors are not provided)

Important note: when DMX is available a red dot will illuminate on the right hand of the display.When red dot is off no DMX signal is available.

WARNING ! Before powering Lites F200 II ensure that all installation(s) procedure(s) have(s) been properly set and accomplished

XLR5 connection	
leads	description
1	GND
2	DMX-
3	DMX+
4	NC
5	NC

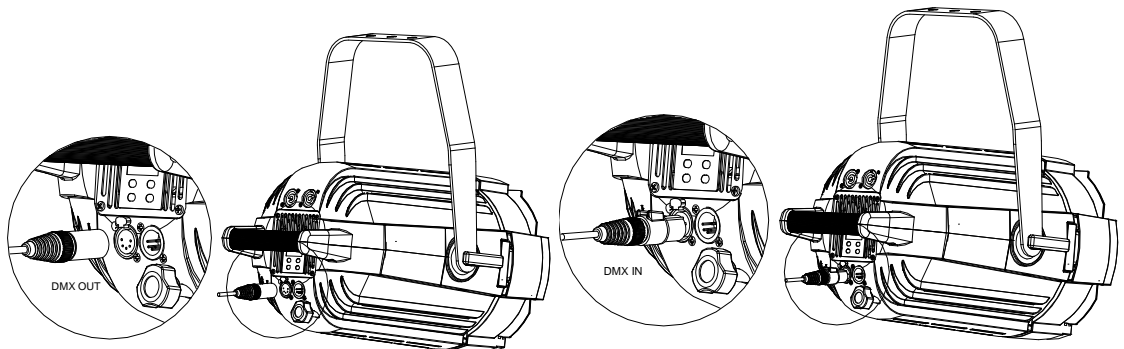

RDM – Remote Device Management

RDM Controller allows for remote standard operations

RDM default options include:

Discovery mode: RDM is engaged when controller incepts this mode, the device reports itself by giving a flash of light (Controller sets the device in a listing to read: settings, DMX address, personality settings, (Read all DMX mode including all DMX channels above)

ON/OFF "Identify": This mode is used to identify the manufacturer's device (Lites srl). It gives a flash of light from the LED

Model information (LITES 200 BUCK)

Software version information (LITES 200 BUCK v.1.xx)

Mode to reveal temperatures of the LED and of the driver

Mode to reveal hour-meters of the LED and of the device

The device allows RDM protocol, ANSI E1.20–010 version

RDM Device Model ID			
5445:1205xxxx			

The following parameters are allowed:

<i>Denominazione Plasa/ESTA</i>	<i>RDM PID Value</i>	<i>Get</i>	<i>Set</i>	<i>Descrizione</i>
CATEGORY – NETWORK MANAGMENT				
DISC UNIQUE BRANCH	0x0001			Message related to Discovery RDM process
DISC MUTE	0x0002			Message related to Discovery RDM process
DISC UN MUTE	0x0003			Message related to Discovery RDM process
CATEGORY – RDM INFORMATION				
SUPPORTED PARAMETERS	0x0050	X		List of allowed parameters
PARAMETER DESCRIPTION	0x0051	X		Parameters description <i>Manufacturer specific</i>
CATEGORY – PRODUCT INFORMATION				
DEVICE INFO	0x0060	X		Reading of following parameters: - Protocol RDM version - Device Model ID - Product category - sw version ID - number of DMX channels - DMX mode index - DMX address - number of sensors
DEVICE MODEL DESCRIPTION	0x0080	X		Text description <i>device model</i> LITES 200 BUCK
MANUFACTURER LABEL	0x0081	X		Text description <i>manufacturer</i> LITES
SOFTWARE VERSION LABEL	0x00C0	X		Text description <i>sw version</i> LITES 200 BUCK v.1.xx
CATEGORY – DMX512 SETUP				
DMX PERSONALITY	0x00E0	X	X	DMX mode setting
DMX PERSONALITY DESCRIPTION	0x00E1	X		Text description DMX mode
DMX START ADDRESS	0x00F0	X	X	DMX address setting/reading
CATEGORY – SENSORS				
SENSOR DEFINITION	0x0200	X		Value related to the sensor
SENSOR VALUE	0x0201	X	X	Parameter for the visualisation of values read by [Board / Led Temperature °C]
CATEGORY – DIMMER SETTINGS (ADDITIONAL MESSAGES)				
CURVE	0x0343	X	X	Parameter for gamma correction (gamma) selection
CURVE DESCRIPTION	0x0344	X		Description of gamma correction parameter
OUTPUT RESPONSE TIME	0x0345	X	X	Parameter related to output smoothness (smooth)
OUTPUT RESPONSE TIME DESCRIPTION	0x0346	X		Output smoothness parameter description
MODULATION FREQUENCY	0x0347	X	X	Parameter related to the selection of pmw signal frequency
MODULATION FREQUENCY DESCRIPTION	0x0348	X		Description of parameter related to the selection of pmw signal frequency
CATEGORY – POWER/LAMP SETTINGS				
DEVICE HOURS	0x0400	X		Parameter related to the reading of device lifespan
LAMP HOURS	0x0401	X		Parameter related to the reading of maximum value hours of led ignition [max between LED1...LED6]
CATEGORY – CONTROL				
IDENTIFY DEVICE	0x1000	X		Flashing LEDs to allow visual identification of the device
CATEGORY – MANUFACTURER-SPECIFIC PIDS				
BOOST	0x9000	X	X	Read/Write BOOST value
FAN MODE	0x9001	X	X	Read/Write FAN MODE value

RDM Parameters – Values

Name	Valid Values	Value Description
ADDITIONAL MESSAGES		
CURVE	1	Read / Write GAMMA value 1 = LINEAR
	2	2 = QUADRATIC [DEF]
	3	3 = S-CURVE
	4	4 = GAMMA 2.2
OUTPUT RESPONSE TIME	1	Read / Write SMOOTH value 1 = SMOOTH 0 → FAST [250 ms]
	2	2 = SMOOTH 1 → MEDIUM [450ms] [DEF]
	3	3 = SMOOTH 2 → SLOW [800 ms]
	4	4 = SMOOTH 3 → SUPER FAST [15 ms]
MODULATION FREQUENCY	1	Read / Write PWM FREQUENCY value 1 = 1 kHz
	2	2 = 2 kHz
	3	3 = 3 kHz
	4	4 = 4 kHz
	5	5 = 5 Hz
	6	6 = 6 kHz
	7	7 = 7 kHz
	8	8 = 8 kHz
	9	9 = 9 kHz
	10	10 = 10 kHz [DEF]
CATEGORY – MANUFACTURER-SPECIFIC PIDs		
BOOST	0	Read/Write BOOST value 0 = OFF [75%] [DEF]
	1	1 = ON [90%]
FAN MODE	0	Read/Write FAN MODE value 0 = AUTO
	1	1 = MEDIUM HIGH [DEF]
	2	2 = MEDIUM LOW
	3	3 = LOW

Projector mode settings

When Lites F200 II is powered, setup-display will show the software release version. The UP, DOWN, ENTER and ESC buttons will allow the operations of the Lites F200 II menu. UP and DOWN buttons allow to scan menu options, ENTER button allow to select. The ESC button is to return to the previous menu or to quit the previous setting.

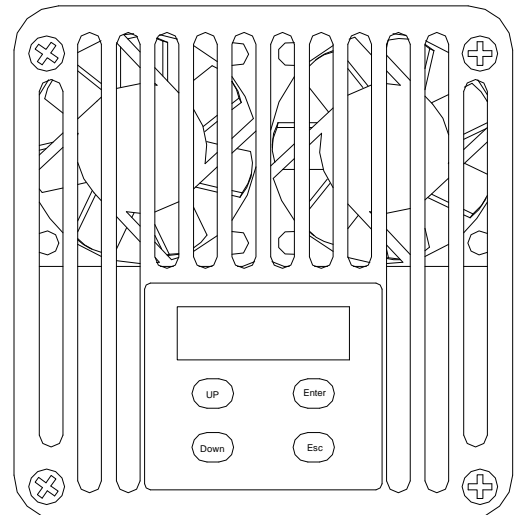

Menu items

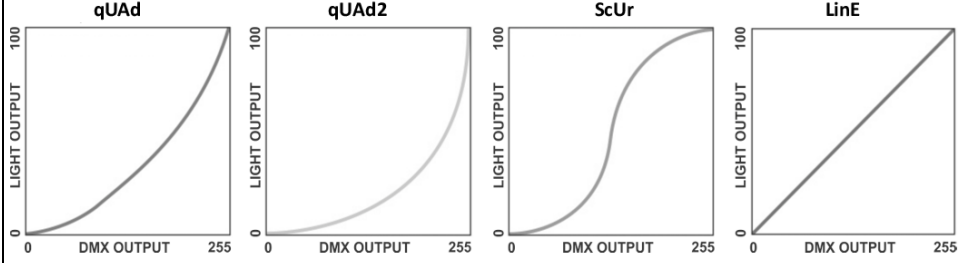
Displayed message	Allowed or displayed values	Mode
Addr	001..510	DMX address : as of 1 to 510
Mode	1 ch 2 ch 3 ch 4 ch 5 ch	DMX Operating mode (see next page)
Man	0..255	Manual light output adjustment (This is possible even if no DMX is resent). Adjusted value will be stored on the internal permanent memory
drUt	..°C	Shows driver operating temperature
LEdt	..°C	Show led operating temperature
PUM	0..100%	Shows current led power (0-100%)
SMOO	SFAST FAST MED SLOW	DMX data Speed adjustment
GAMM	qUAd SCUr qUAd2 LIInE	 <p>Dimming curves available</p>
FrEq	1K 2K 3K 4K 5K 6K 7K 8K 9K 10K	LED operation frequency
booS	Off on	Boost selection: off = maximum led power at 90% on = maximum led power at 100%
FAN	Aut MEDH MEDL LOW	4 fan operating modes i.e automatic, medium fast, medium slow, slow speed. Fan speed adjustments (fan-sound) reflect on self-correct output LED brightness and other factors as room-temperature, number of engaged channels
PoS	AA VV	I Display orientation selection: AA = normal VV = inverted
StbY	Off on	Standby display activity: off = display always switched on on = display switched off after few seconds of buttons inactivity (only the right side dot will be lighted to indicate DMX availability)
dEF	Off on	ON Will restore the default factory values
SoFt		Shows Software version

DMX Operating Modes (Mode)

Lites F200 II provides with different DMX operating modes ensuring the ideal use of the DMX universe
Shutter/strobo, 8/16 bit dimmer, fan speed and LED frequency are all adjustable

mode a 1ch

Ch	funzione	Livelli dmx	
1	dimmer	0..255	Light output: 0=Off, 255=Maximum Power

mode a 2ch

Ch	funzione	Livelli dmx	
1	shutter	0-9	off
		10..255	Strobe effect from slow to fast
2	dimmer	0..255	Light output: 0=Off, 255=Maximum Power

mode a 3ch

Ch	function	dmx values	
1	shutter	0-9	off
		10..255	Strobe effect from slow to fast
2	dimmer	0..255	Light output: 0=Off, 255=Maximum Power
3	Fan speed	0..25	Auto speed or set from menu
		26..49	Fan off
		50..255	Fan adjustment from minium to max value

mode a 4ch

Ch	function	dmx values	
1	shutter	0..9	off
		10..255	Strobe effect from slow to fast
2	dimmer	0..255	Light output: 0=Off, 255=Maximum Power
3	Fan speed	0..25	Auto speed or set from menu
		26..49	Fan off
		50..255	Fan adjustment from minium to max value
4	LED Frequency Modulation (flickering)	0..24	PWM Frequency 1KHz
		25..49	PWM Frequency 2KHz
		50..74	PWM Frequency 3KHz
		75..99	PWM Frequency 4KHz
		100..124	PWM Frequency 5KHz
		125..149	PWM Frequency 6KHz
		150..174	PWM Frequency 7KHz
		175..199	PWM Frequency 8KHz
200..224	PWM Frequency 9KHz		
225..255	PWM Frequency 10KHz		

mode a 5ch

Ch	function	dmx values	
1	shutter	0..9	off
		10..255	Strobe effect from slow to fast
2	dimmer	0..255	Light output: 0=Off, 255=Maximum Power
3	Dimmer fine	0..255	0..255 fine dimmer adjustment
4	Fan speed	0..25	Auto speed or set from menu
		26..49	Fan off
		50..255	Fan adjustment from minium to max value
5	LED Frequency Modulation (flickering)	0..24	PWM Frequency 1KHz
		25..49	PWM Frequency 2KHz
		50..74	PWM Frequency 3KHz
		75..99	PWM Frequency 4KHz
		100..124	PWM Frequency 5KHz
		125..149	PWM Frequency 6KHz
		150..174	PWM Frequency 7KHz
		175..199	PWM Frequency 8KHz
200..224	PWM Frequency 9KHz		
225..255	PWM Frequency 10KHz		

Error messages

In case of malfunction, the following messages may be shown:

LED ERROR : sympton of a possible short-circuit on LED driver.

TEMPERATURE ERROR: sympton that sensors have measured temperature below -15°C or failure on NTC- in such event LED will switch to off mode. Should any of the above given messages occur, for precaution measures the LED will always switch to off mode. Halt the unit immediately and refrain from the use of it and promptly contact any authorized service centre.

Periodical maintenance

To ensure the correct Lites F200 II 's operations we suggest the following periodical maintenance operations:

Remove dust or any kind of other dirty from the fans and loop-holes to ensure the correct air flow

Remove dust from lenses using a clean cloth. This maintenance will ensure the maximum light efficiency

Replace damaged protection screens and lenses when necessary

Always handle LitesF200 gently and with care, do not drop, do not shake do not cause shocks to the unit as it could damage it irremediably.

Do not touch nor clean the LED as well as the yellow area around it with solvents

Device disposal information

At the end of its life, Lites F200 II must be disposed to an appropriate electrical and electronic equipment waste collection centre. Eco-friendly disposal, helps to avoid possible negative impact on the environment and human health and promotes the reuse and/or recycling of the materials making up the product. Illegal disposal involves administrative sanctions provided by laws enacted.



Manufacture declines any sort of personal/corporate responsibility/liability for damages caused by the inadequate use of the product as well as if unqualified personnel have handled the product. Not complying with security norms/periodical maintenance as expressed in the owner's/service manual will also totally free personal/corporate responsibility/liability.