

Lites

HPLLED AR T

Tunable 3000°-5700°k

Retrofit for Fresnel
Arri Studio 2000

Owner's and service manual



Read this manual totally and carefully follow all the instructions contained. File this manual for future use. It is essential to read all the information contained to ensure correct installation, service and full operation of the HPLLED AR T
All operations must be accomplished, handled and carried out by qualified personnel only.

NOT COMPLYING WITH GIVEN NOTICE IT WILL VOID WARRANTY AND WILL FREE THE MANUFACTURER OF ANY KIND OF RESPONSIBILITY AND LIABILITY.

Unpacking

Unpack the carton and gently remove HPLED AR T from the box. Ensure HPLED AR T is received in all its parts. In the event the HPLED AR shows any damage, do not use it and contact immediately your transporter as well as your seller. Items in the carton consist of:

- N. 1 HPLED AR T unit
- N. 1 Ø 3 mm washers
- N. 1 M3 screws
- N. 2 Ø 4 mm washers
- N. 2 M4 screws

Installation, utilisation and service owner's manual.



General Information and recommendation to operate the unit in good and safe conditions.

Follow instructions with care and attention:

HPLED AR T must be used and housed only and exclusively for the 2000W Arri Studio 2000 unit

The HPLED AR T unit must NEVER be used unless it is housed in one of the models listed above. (Fresnel ARRI Studio 2000).

HPLED AR T fixture is only meant for professional use. NEVER use it for domestic or other improper use.

Minimum distance from any flammable source is of 0.25m.

Minimum throw distance from illuminated surface: 0.5m.

The installation of the unit(s) (prior to installation, the HPLED AR T unit must be housed in one of the Arri Studio 2000 luminaires listed above), the housing of the external fixture body, must be secured with suitable clamps, safety cords and adequate protection.

Install HPLED AR T in ventilated ambient which temperature must not exceed 35°C

HPLED AR is NOT for domestic use, HPLED AR can only be used for professional applications.

When HPLED AR T unit is operated, some outer parts of the profile can reach temperatures of up to 60°C

HPLED AR must be fitted with protection shields (Lense)

On no account, directly or indirectly, LED must be touched as it may impair its use.

An Essential and Periodically throughout cleaning of the HPLED AR is recommended. This practice avoids that layers of dust and other impurity jeopardise and reduce the correct operation of the unit. Lense must be cleaned to remove layers of dust that may impede and or reduce the passage of the light through the lenses. The correct and periodically maintenance keeps also fans and vents clean thus keeping the HPLED AR in its best performance conditions. Never touch, directly or indirectly, the Yellow core of the LED nor use solvents that can damage the LED irremediably. Protection shields if battered/worn, must be replaced with new ones (Lenses)



Warning from electric shocks

All operations must be accomplished, handled and carried out by qualified personnel only

Warning High voltage hazard, always disconnect Power before any handling and any servicing of HPLED AR T

Do not and never handle HPLED AR T with humid/wet hands or near to any water or any kind of moisture sources

Always connect HPLED AR T to mains fitted with safety device switch that cuts power off in case of danger

The HPLED AR T does NOT and CAN NOT be operated via Phase control dimmer nor connected/operated in NON-DiM mode

HPLED AR T is rated Class I

Earth connection is mandatory!

CE Approvals

The HPLED AR T products to which this manual refers to, complies with European directive pursuant to:

2014/35/EU safety of electrical equipment supplied at low voltage (LVD)

2014/30/EU Electromagnetic compatibility (EMC)

2011/65/EU Restriction of the use of certain hazardous substances (RoHS)

WARRANTY!

A 24-month warranty is granted on the HPLED AR T from purchase's date. Warranty covers fabrication defects only. Warranty is immediately voided if the HPLED AR T has been handled by unqualified personnel. Any improper and unauthorised use, such modification(s) or misapplication of the HPLED AR T will also void the warranty of the product(s). Silver colour label showing technical data and serial number, if removed or if data are impaired to render details illegible, it will immediately void the warranty

Technical specifications

Power Supply 100-240 V~ 50/60Hz

Maximum power consumption 180W

Minimum ambient temperature -10°C

Maximum ambient temperature 35°C

LED Colour Temperature: 3000°K - 5700°K

LED CRI 96 (3000°K) and 94 (5700°K)

LED Life (see Manufacturers ' specifications)

Weight: 2,35 Kg

IP rating 20: To be housed into original Arri Studio 2000 luminaire

Working position: Any

Data connectors: IN & OUT XRL5

Data protocols: DMX 512; RDM ready

User interface: 4-digit display and 2 buttons

Manual operation: Users must operate via buttons provided on the display

Fan control: Fan speed adjustment

Control of LED frequency: Selection of LED frequency refresh

2 Dimming curves control: Selection of four dimming curves control

Compliant: **CE**

Dimensions (see picture):

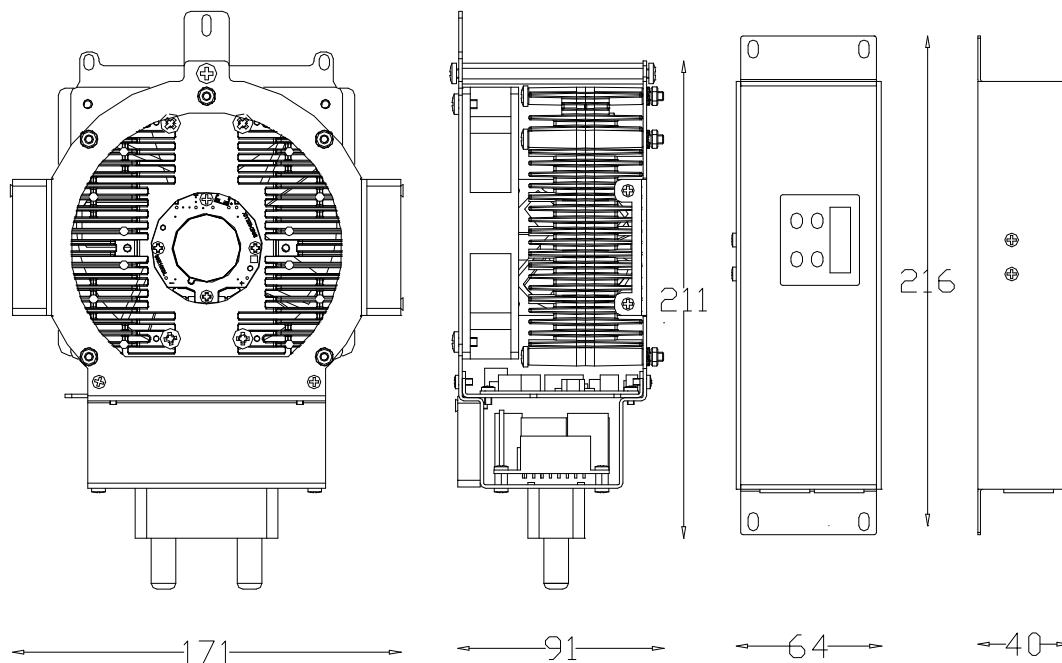

⚠ It is mandatory to disconnect power from mains during the whole process installation of the HPLED AR T module.

The HPLED AR T module is designed to replace the halogen lamps used in Fresnel Arri Studio 2000 projectors. Open the front door of the projector (see fig. 1). Use the zoom knob to slide the lamp holder carriage all the way forwards. Remove the reflector by unscrewing the 2 M4 screws (see fig. 2-3). Remove the side plate by unscrewing the 4 screws. (see fig. 4-5-6). Insert the module into the lamp holder and secure it by turning the lever in the lamp holder. Fix the module with the two M4 screws + toothed washer to the holes that previously supported the reflector (see fig. 7). Insert the cables of the module into the side bulkheads of the projector so that the cables protrude to the side (see fig.8-9). Connect the DMX cables and the display strip to the respective connectors. Secure the signal cables with the supplied cable tie. Screw the dmx display-connector box to the projector with the 4 M4 screws (see fig.10-11).



Fig.1



Fig.2



Fig.3



Fig.4



Fig.5



Fig.6



Fig.7



Fig.8

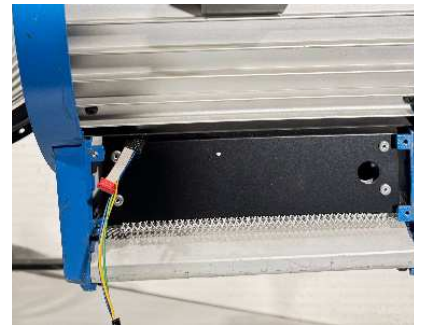

Fig.9

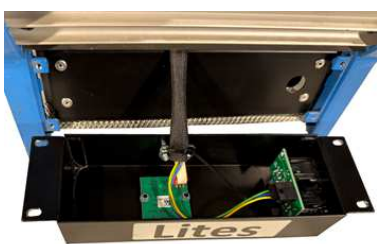

Fig.10



Fig.11



Fig.12

Connection to mains

WARNING ! Installation(s) must be accomplished, handled and carried out by qualified personnel only and must comply with all norms in force in the installation's country

Power up the projector using the supplied cable.

WARNING:NEVER CONNECT HPLED RJ ENGINE TO ANGLE PHASE DIMMER PACK NOR TO NON-DIM MODE

Signal control connection

HPLED AR T can be operated via either DMX512A and or RDM ready Protocols. For Daisy chain DMX line use a-2 lead wire plus shield.

Important note: when DMX is available a red dot will illuminate on the right hand of the display. When red dot is off no DMX signal is available.

Collegamento co connettore XLR5	
poli	descrizione
1	GND
2	DMX-
3	DMX+
4	NC
5	NC



RDM – Remote Device Management

RDM Controller allows for remote standard operations.

RDM default options include:

Discovery mode: RDM is engaged when controller incepts this mode, the device reports itself by giving a flash of light (Controller sets the device in a listing to read: settings, DMX address, personality settings, (Read all DMX mode including all DMX channels above)

ON/OFF "Identify": This mode is used to identify the manufacturer's device (Lites srl).

It gives a flash of light from the LED. Model information (HPLED II T)

Software version information (HPLED II -T v.x.xx)

Mode to reveal temperatures of the LED and of the driver

Mode to reveal hour-meters of the LED and of the device

The device allows RDM protocol, ANSI E1.20–010 version

RDM Device Model ID				
5445:120Fxxxx				

The following parameters are allowed:

<i>Denominazione Plasa/ESTA</i>	<i>RDM PID Value</i>	<i>Get</i>	<i>Set</i>	<i>Descrizione</i>
CATEGORY – NETWORK MANAGMENT				
DISC UNIQUE BRANCH	0x0001			Message related to Discovery RDM process
DISC MUTE	0x0002			Message related to Discovery RDM process
DISC UN MUTE	0x0003			Message related to Discovery RDM process
CATEGORY – RDM INFORMATION				
SUPPORTED PARAMETERS	0x0050	X		List of allowed parameters
PARAMETER DESCRIPTION	0x0051	X		Parameters description <i>Manufacturer specific</i>
CATEGORY – PRODUCT INFORMATION				
DEVICE INFO	0x0060	X		Reading of following parameters: - Protocol RDM version - Device Model ID - Product category - sw version ID - number of DMX channels - DMX mode index - DMX address - number of sensors
DEVICE MODEL DESCRIPTION	0x0080	X		Text description <i>device model HPLED-II-DW</i>
MANUFACTURER LABEL	0x0081	X		Text description <i>manufacturer LITES</i>
SOFTWARE VERSION LABEL	0x00C0	X		<i>Text description sw version HPLED-II-DW v.1.xx</i>
CATEGORY – DMX512 SETUP				
DMX PERSONALITY	0x00E0	X	X	DMX mode setting
DMX PERSONALITY DESCRIPTION	0x00E1	X		Text description DMX mode
DMX START ADDRESS	0x00F0	X	X	DMX address setting/reading
CATEGORY – SENSORS				
SENSOR DEFINITION	0x0200	X		Value related to the sensor
SENSOR VALUE	0x0201	X	X	Parameter for the visualisation of values read by [Board / Led Temperature °C]
CATEGORY – DIMMER SETTINGS (ADDITIONAL MESSAGES)				
CURVE	0x0343	X	X	Parameter for gamma correction (gamma) selection
CURVE DESCRIPTION	0x0344	X		Description of gamma correction parameter
OUTPUT RESPONSE TIME	0x0345	X	X	Parameter related to output smoothness (smooth)
OUTPUT RESPONSE TIME DESCRIPTION	0x0346	X		Output smoothness parameter description
MODULATION FREQUENCY	0x0347	X	X	Parameter related to the selection of pmw signal frequency
MODULATION FREQUENCY DESCRIPTION	0x0348	X		Description of parameter related to the selection of pmw signal frequency
CATEGORY – POWER/LAMP SETTINGS				
DEVICE HOURS	0x0400	X		Parameter related to the reading of device lifespan
LAMP HOURS	0x0401	X		Parameter related to the reading of maximum value hours of led ignition [max between LED1...LED6]
CATEGORY – CONTROL				
IDENTIFY DEVICE	0x1000	X		Flashing LEDs to allow visual identification of the device
CATEGORY – MANUFACTURER-SPECIFIC PIDs				
BOOST	0x9000	X	X	Read/Write BOOST value
FAN MODE	0x9001	X	X	Read/Write FAN MODE value

RDM Parameters – Values

<i>Name</i>	<i>Valid Values</i>	<i>Value Description</i>
ADDITIONAL MESSAGES		
CURVE	1 2 3 4	Read / Write GAMMA value 1 = LINEAR 2 = QUADRATIC [DEF] 3 = S-CURVE 4 = GAMMA 2.2
OUTPUT RESPONSE TIME	1 2 3 4	Read / Write SMOOTH value 1 = SMOOTH 0 → FAST [250 ms] 2 = SMOOTH 1 → MEDIUM [450ms] [DEF] 3 = SMOOTH 2 → SLOW [800 ms] 4 = SMOOTH 3 → SUPER FAST [15 ms]
MODULATION FREQUENCY	1 2 3 4 5 6 7 8 9 10	Read / Write PWM FREQUENCY value 1 = 1 kHz 2 = 2 kHz 3 = 3 kHz 4 = 4 kHz 5 = 5 Hz 6 = 6 kHz 7 = 7 kHz 8 = 8 kHz 9 = 9 kHz 10 = 10 kHz [DEF]
CATEGORY – MANUFACTURER-SPECIFIC PIDs		
BOOST	0 1	Read/Write BOOST value 0 = OFF [75%] [DEF] 1 = ON [90%]
FAN MODE	0 1 2 3	Read/Write FAN MODE value 0 = AUTO 1 = MEDIUM HIGH [DEF] 2 = MEDIUM LOW 3 = LOW

Menu items

Displayed Message	Allowed or displayed values	Function	
Addr	001..512	Set Up DMX Address	
Auto (Automatic mode)	3000 3100 3200 3400 3600 4000 4400 4900 5300 5500 5600 5700	Preset 1 White 3000°k Preset 2 White 3100°k Preset 3 White 3200°k Preset 4 White 3400°k Preset 5 White 3600°k Preset 6 White 4000°k Preset 7 White 4400°k Preset 8 White 4900°k Preset 9 White 5300°k Preset 10 White 5500°k Preset 11 White 5600°k Preset 12 White 5700°k	Values between 3000 through 5700 allow for fixed white set-up without DMX 512 protocol signal. When fixture is turned, the last selected preset will be held. By pressing the Enter button, "U" appears on the display and using the UP and Down buttons you can adjust the white tone. By pressing the ENTER key, the message D will appear and by using the UP and Down keys it will be possible to adjust the output brightness from 0 to 255. Once the preset has been modified, the dot at the bottom right of the display will flash.
	Pr01 Pr02	Program 1: auto Program 2 : auto	Automatic mode without DMX 512 Protocol signal. Program selections run between Pr01 through Pr 02 Both programs can be modified. To change program select Enter then view (Scn0...Scn9; max scenes of each program). Clicking on enter once more it shows P.00.0 (time) followed by F.00.0 (speed) and ultimately the last view shows 1c.01... though c12 (colour to be assigned to each scene) The use of UP/Down keys allow for setting values. When selections are completed press enter to confirm
MaSL	Master Mode	The Master Mode uses the same settings as the Auto Menu. The only exception is that when all fixtures are connected to DMX 001 in daisy-chain, they perform the same presets and or the same presets selected on the Master fixture. .(Slave devices must be set in Mode 2ch)	
Mode	2 ch	3000/5700 °K	Dmx mode (view next page)
	2 ch (D)	3000/5700°K -dimmer (default)	
	3 ch	3000/5700°k-dimmer- strobo	
	4 ch	3000/5700°k-dimmer16(bit) strobe	
	9 ch	3000/5700°k setting options	
drUt	..°C	Shows driver operating temperature	
LEdt	..°C	Shows leds operating temperature	
PUM	0..100%	Shows current led power (0-100%)	
SMOO	SFSt FAST MED SLOW	DMX data Speed adjustment	
GAMM	qUAd SCUr qUAd2 LInE		
		Dimming curves available	

FREQ	1K 2K 3K 4K 5K 6K 7K 8K 9K 10K	LED operation frequency
booS	Off on	When OFF, LED max flux : 90% When ON, LED max flux : 100%
FAn	Aut MEDH MEDL LOW	4 fan operating modes i.e automatic, medium fast, medium slow, slow speed. Fan speed adjustments (fan-sound) reflect on self-correct output LED brightness and other factors as room-temperature, number of engaged channels
PoS	AA VV	Display orientation selection: AA = normal VV = inverted
StbY	Off on	Standby display activity: off = display always switched on = display switched off after few seconds of buttons inactivity (only the right side dot will be lighted to indicate DMX availability)
dEF	Off on	ON Will restore the default factory values
SoFt		Shows Software version

DMX Operating Modes (Mode)

HPLED AR T provides with different DMX operating modes ensuring the ideal use of the DMX universe Shutter/strobo, 8/16 bit dimmer, fan speed and LED frequency are all adjustable

mode 2 ch white indipendenti

Ch	funzione	Livelli dmx	
1	3000°k White	0..255	From 0 to max 255
2	5600°k White	0..255	From 0 to max 255

mode 2 ch (default)

Ch	funzione	Livelli dmx	
1	3000°k-5600°k	0..255	When set to level 0 = 3000°k – When set to level 255 = to 5600°k
2	dimmer	0..255	From 0 to max 255

mode 3 ch dimmer

Ch	funzione	Livelli dmx	
1	3000°k-5600°k	0..255	When set to level 0 = 3000°k – When set to level 255 = to 5600°k
2	dimmer	0..255	From 0 to max 255
3	shutter	0-9	Strobe disengaged
		10..255	Strobe from slow (10) to fast (255)

mode 4 ch dimmer 16 bit

Ch	funzione	Livelli dmx	
1	3000°k-5700°k	0..255	When set to level 0 = 3000°k – When set to level 255 = to 5700°k
2	dimmer	0..255	From 0 to max 255
3	Dimmer fine	0..255	From 0 to max 255
4	shutter	0-9	Strobe disengaged
		10..255	Strobe from slow (10) to fast (255)

mode 9 ch "w9ch" (setting options)

Ch	Function	dmx levels	
1	3000°k White	0..255	From 0 to max 255
2	5700°k White	0..255	From 0 to max 255
3	dimmer	0..255	From 0 to max 255
4	Dimmer fine	0..255	From 0 to max 255
5	shutter	0-15	Strobe disengaged
		16..255	Strobe from slow (16) to fast (255)
6	DMX data Speed adjustment	0..24	values selected from display
		25..74	SLOW
		75..124	MED
		125..174	FAST
		175..224	SFAST
		225..255	(reserved)
7	Dimming curves available	0..24	values selected from display
		25..74	qUAd
		75..124	SCUr
		125..174	qUAd2
		175..224	LInE
		225..255	(reserved)
8	Frequency Modulation (LED PWM Freq.)	0..39	values selected from display
		40..54	(reserved)
		55..69	PWM Frequency 1KHz
		70..84	PWM Frequency 2KHz
		85..99	PWM Frequency 3KHz
		100..114	PWM Frequency 4KHz
		115..129	PWM Frequency 5KHz
		130..144	PWM Frequency 6KHz
		145..159	PWM Frequency 7KHz
		160..174	PWM Frequency 8KHz
		175..189	PWM Frequency 9KHz
		190..204	PWM Frequency 10KHz
		205..219	(reserved)
		220..255	(reserved)
		9	BOOST
25..124	OFF		
125..224	ON		
225..255	(reserved)		

Error messages

In case of malfunction, the following messages may be shown:

LED ERROR : sympton of a possible short-circuit on LED driver.

TEMPERATURE ERROR: sympton that sensors have measured temperature below -15°C or failure on NTC- in such event LED will switch to off mode. Should any of the above given messages occur, for precaution measures the LED will always switch to off mode. Halt the unit immediately and refrain from the use of it and promptly contact any authorized service centre.

Periodical maintenance

To ensure the correct HPLED AR T 's operations we suggest the following periodical maintenance operations:

Remove dust or any kind of other dirty from the fans and loop-holes to ensure the correct air flow

Remove dust from lenses using a clean cloth. This maintenance will ensure the maximum light efficiency

Replace damaged protection screens and lenses when necessary

Always handle HPLED AR T gently and with care, do not drop, do not shake do not cause shocks to the unit as it could damage it irremediably.

Do not touch nor clean the LED as well as the yellow area around it with solvents

Device disposal information

At the end of its life, HPLED AR T must be disposed to an appropriate electrical and electronic equipment waste collection centre. Eco-friendly disposal, helps to avoid possible negative impact on the environment and human health and promotes the reuse and/or recycling of the materials making up the product. Illegal disposal involves administrative sanctions provided by laws enacted.



Manufacture declines any sort of personal/corporate responsibility/liability for damages caused by the inadequate use of the product as well as if unqualified personnel have handled the product. Not complying with security norms/periodical maintenance as expressed in the owner's/service manual will also totally free personal/corporate responsibility/liability.

HPLED AR T 30/01/2025 rev.00